

PVI-275.0/330.0

General Specification Centralized Model PVI-275.0/PVI-275.0-TL PVI-330.0/PVI-330.0-TL

AURORA BENEFITS

- Scalable architecture based on independent 55kW conversion modules
- Flexible system architecture with two functionally independent 55kW modules, configurable in "Master-Slave" mode (modules in parallel) or "Multi-Master" mode (independent modules).
- New "Electrolyte-free" power converter to further increase the life expectancy and long term reliability
- Reduced susceptibility to a single fault. In case of a component failure, a maximum of 55kW will be lost
- Increased energy harvesting, Euro and peak efficiency +0,5% compared to previous generation (η_{pk} PVI-275.0/330.0-TL=98,0%)
- Reduced acoustic noise due to the high switching frequency (18kHz).
- Maximum input voltage up to 1000Vdc, improved design flexibility and reduced DC distribution losses for large scale PV plants
- Integrated DC and AC distribution and protection. Fully equipped for connection, additional accessories not required
- Simplified wiring, fully front-accessible DC and AC terminations
- Easy installation and maintenance procedure. Front extractible DC distribution and auxiliary supply drawers, together with the modular DC/AC converters ensure full accessibility to all critical parts during installation, inspection and maintenance (incl. air filter holders)
- Smart grid management functions for large "utility grade" PV plants. Static grid support through reactive power compensation, frequency-dependent control of active power, utility-controlled active and reactive power set-points, dynamic grid support with LVRT capability (Low Voltage Ride Through). All optional functions available in accordance to the BDEW medium-voltage directive
- Also available without isolation transformer (TL version) for direct connection to the medium voltage network (through dedicated MT transformer)
- Low common mode noise technology: multiple TL inverters are parallelable across the same secondary winding of medium voltage transformer



BLOCK DIAGRAM - 275.0/330.0KW

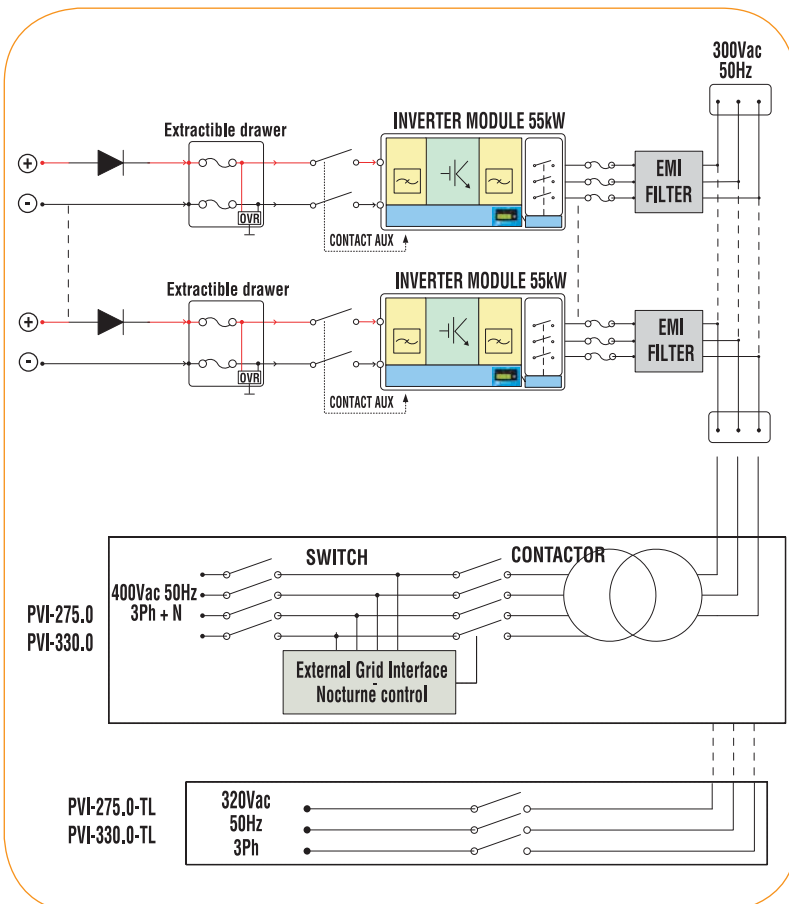

AURORA PVI-275.0/330.0 EFFICIENCY

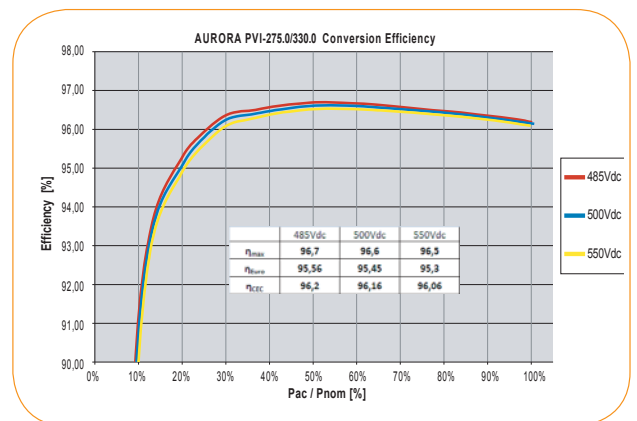

AURORA PVI-275.0/330.0-TL EFFICIENCY

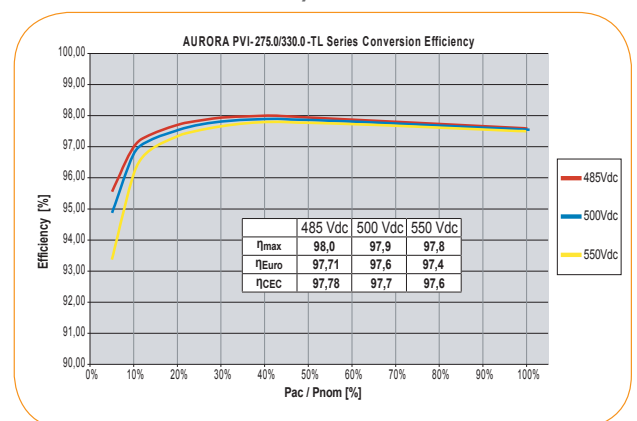

CHARACTERISTICS	PVI-275.0-EN	PVI-275.0-TL-EN	PVI-330.0-EN	PVI-330.0-TL-EN
INPUT PARAMETERS				
Nominal PV power [kWp]	282	282	338,4	338,4
Maximum recommended PV power [kWp]				
Total (master/slave mode)	295	295	354	354
Per channel (multi-master mode)	59	59	59	59
Absolute maximum input voltage [Vdc]	1000	1000	1000	1000
MPPT input voltage range ⁽¹⁾ [Vdc]	485 - 850	485 - 850	485 - 850	485 - 850
Number of independent MPPT				
Multi-master configuration	5	5	6	6
Multi-master/slave configuration	3	3	3	3
Master/slave	1	1	1	1
Total Maximum input current [A _{dc}]	615	615	738	738
Multi-master mode (each module)	123	123	123	123
Input Reflected Ripple voltage	< 3%	< 3%	< 3%	< 3%
Number of DC inputs	5	5	6	6
Max. DC input wire section (each polarity) ⁽²⁾	3x185mmq + 2x300mmq (M10)	3x185mmq + 2x300mmq (M10)	3x185mmq + 3x300mmq (M10)	3x185mmq + 3x300mmq (M10)
STANDARD EQUIPMENT - INPUT				
Insulation Control	Yes, with alarm	Yes, with alarm	Yes, with alarm	Yes, with alarm
Integrated DC protection				
Reverse polarity and backfeed current protection (each input)	YES, with series diode	YES, with series diode	YES, with series diode	YES, with series diode
Input fuse overcurrent protection ⁽³⁾ (each input/both polarities)	125A/1000V	125A/1000V	125A/1000V	125A/1000V
Load-breaking DC switch ⁽⁴⁾ (each input, monitored)	200A/1000V	200A/1000V	200A/1000V	200A/1000V
Input overvoltage protection ⁽⁵⁾ (monitored)	Yes	Yes	Yes	Yes
OUTPUT PARAMETERS				
Nominal AC Output Power, PAC _{nom} (up to 50°C, kW)	275	275	330	330
Nominal AC Output Current [Arms]	405	505	486	606
AC Output Voltage range [Vrms]	3 x 400 +/-15%	3 x 320 +/-20%	3 x 400 +/-15%	3 x 320 +/-20%
Nominal AC Frequency [Hz]	50 / 60	50 / 60	50 / 60	50 / 60
Nominal Power Factor / adjustment range [cos φ]	1 / -0.95...+0.95 (@ Pac nominal)	1 / -0.95...+0.95 (@ Pac nominal)	1 / -0.95...+0.95 (@ Pac nominal)	1 / -0.95...+0.95 (@ Pac nominal)
AC Current Harmonics [THD%] ⁽⁶⁾	< 3% (@ Pac nominal)	< 3% (@ Pac nominal)	< 3% (@ Pac nominal)	< 3% (@ Pac nominal)
Inverter Switching Frequency [kHz]	18	18	18	18
Max AC output wire section (each phase)	1x240mmq (M12)	2x300mmq (M12)	1x240mmq (M12)	2x300mmq (M12)
STANDARD EQUIPMENT - OUTPUT				
AC Contactor (night time disconnect)	No	No	No	No
AC Output Circuit Breaker (Magnetothermal switch) / Breaking capacity [kA] (* 300Vac side of the transformer)	Yes (*) / 50kA	Yes / 50kA	Yes (*) / 50kA	Yes / 50kA
AC side overvoltage protection (power and aux input)	Yes	Yes	Yes	Yes
CONVERSION EFFICIENCY⁽⁷⁾				
Peak Efficiency %	96,70%	98,00%	96,70%	98,00%
Euro Efficiency %	95,50%	97,71%	95,50%	97,71%
CEC Efficiency %	96,20%	97,78%	96,20%	97,78%
ENVIRONMENTAL PARAMETERS				
Environmental Protection Degree (acc to EN 60529)	IP20	IP20	IP20	IP20
Operating Temperature Range	-10°C...+50°C	-10°C...+50°C	-10°C...+50°C	-10°C...+50°C
Required ambient air cooling flow	5000m ³ /h	5000m ³ /h	6000m ³ /h	6000m ³ /h
Relative Humidity (non-condensing)	< 95%	< 95%	< 95%	< 95%
Maximum altitude above sea level without derating [m] ⁽⁸⁾	1000	1000	1000	1000
Audible Noise [dBA @ 1m]	<75	<72	<78	<75
AUXILIARY SUPPLY				
External Auxiliary Supply Voltage	3x400Vac + N, 50/60Hz	3x400Vac + N, 50/60Hz	3x400Vac + N, 50/60Hz	3x400Vac + N, 50/60Hz
Maximum consumption in operation	<0.29% PAC _{nom}	<0.24% PAC _{nom}	<0.28% PAC _{nom}	<0.24% PAC _{nom}
Maximum consumption in operation (ac-box fan off)	<0.22% PAC _{nom}	<0.22% PAC _{nom}	<0.22% PAC _{nom}	<0.22% PAC _{nom}
Night time losses [W]	<45W	<40W	<52W	<47W
COMMUNICATION/USER INTERFACE				
Communication Port (PC / Datalogger)	1 x RS485 (RS485 USR)	1 x RS485 (RS485 USR)	1 x RS485 (RS485 USR)	1 x RS485 (RS485 USR)
Communication - String Combiner boxes (PVI-STRINGCOMB)	1 x RS485 (RS485 2)	1 x RS485 (RS485 2)	1 x RS485 (RS485 2)	1 x RS485 (RS485 2)
Remote Communication (optional)	WEBLOGGER, PVI-EAC-EVO (Ethernet, GPRS)	WEBLOGGER, PVI-EAC-EVO (Ethernet, GPRS)	WEBLOGGER, PVI-EAC-EVO (Ethernet, GPRS)	WEBLOGGER, PVI-EAC-EVO (Ethernet, GPRS)
User Interface	2-lines Display (on each inverter module)	2-lines Display (on each inverter module)	2-lines Display (on each inverter module)	2-lines Display (on each inverter module)
MECHANICAL CHARACTERISTICS				
Dimensions (WxHxD) [mm]	1250 x 2116(*) x 893.5	1250 x 2116(*) x 893.5	1250 x 2116(*) x 893.5	1250 x 2116(*) x 893.5
(*) Output Air conduit not included	1250 x 1147(*) x 870 (trafo box)		1250 x 1147(*) x 870 (trafo box)	
Overall Weight [kg]	1600	1000	1700(*)	1100(*)
50kW module Weight [kg]	60	60	60	60
APPROVALS				
EMC	EN 61000-6-2, EN 61000-6-4, EN 61000-3-11; EN 61000-3-12		EN 61000-6-2, EN 61000-6-4, EN 61000-3-11; EN 61000-3-12	
CE Compliance	Yes		Yes	
Grid connection	Connection guide to the Enel grid Ed 1.1/09, BDEW, RD1663/2000		Connection guide to the Enel grid Ed 1.1/09, BDEW, RD1663/2000	

NOTES:

- V_{mp_min} = 485V @ Vac ≤ 320Vrms and cos φ = 1
- Cable crimped with reduced size terminal ring;
For cable up to 185mmq: use terminal ring for M10 screw and max width 30mm
For cable up to 300mmq: use terminal ring for M10 screw and max width 40mm
- Only Master/Slave and Multi-Master/Slave
- For M/S configuration above 110Kw a load breaking disconnect is required at the DC input of the inverter
- Multi-Master = 1 for each input; Master/Slave and Multi-Master/Slave = 1 for each mppt
- AC voltage distortion <2%
- Conversion efficiency, not including auxiliary supply consumption, measured @ V_{dc}=485V and Vac=320Vrms
- Contact Power-One for application at higher altitudes

MODEL SUMMARY

MODEL NUMBER	CONFIGURATION
PVI-275.0	with transformer
PVI-275.0-TL	without transformer
PVI-330.0	with transformer
PVI-330.0-TL	without transformer

PVI-275.0/330.0

FOOTPRINT HOLES FOR DC, AC AND AUX CABLE INPUT

PVI-275.0/330.0-TL-EN

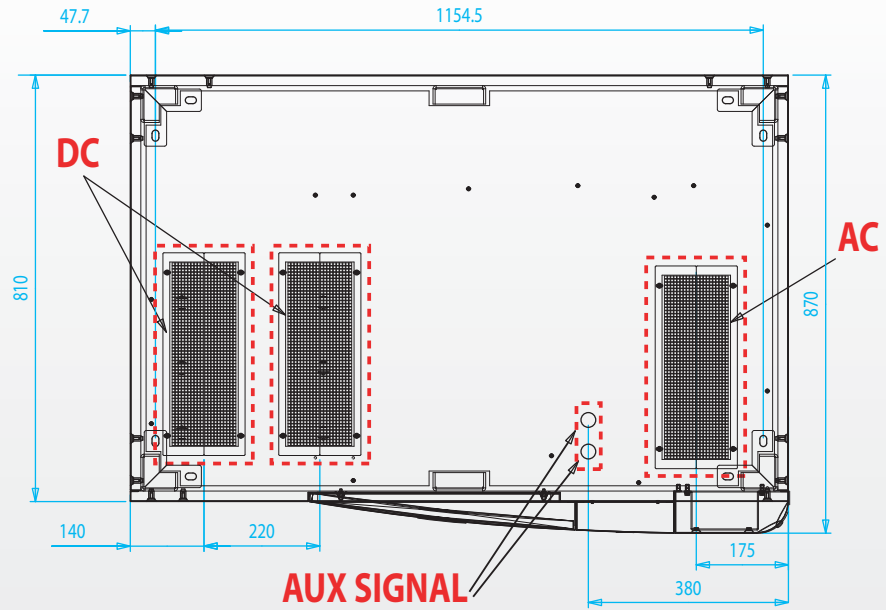

PVI-275.0/330.0-EN

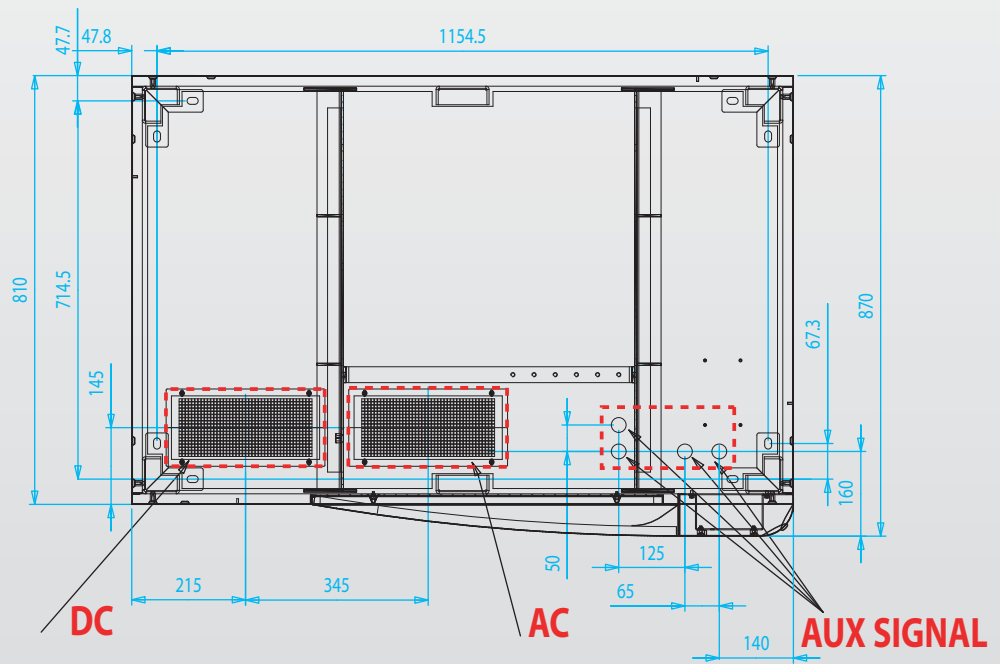

DETAILS OF DC CABLES ALLOCATION



CONFIGURATION PANEL

