

PVI-3.8-I-OUTD / PVI-4.6-I-OUTD

AURORA[®]
Photovoltaic Inverter



General Specifications

Outdoor models

PVI-3.8-I-OUTD/PVI-3.8-I-OUTD-S

PVI-4.6-I-OUTD/PVI-4.6-I-OUTD-S

NEW FEATURES

- High frequency transformer-isolated topology.
- Optimized for use in applications with negative-grounded or positive-grounded PV arrays (thin film modules or “all-back contact” technologies).
- Integrated fuse grounding Kit with ground fault detection and interruption (GFDI in acc. to UL1741). Field-configurable for positive or negative grounding during installation.
- Low leakage current topology. Can be used with high capacitance modules, including thin film laminates on metal substrate and ungrounded PV arrays.
- One model for ALL countries, the Internation inverter. Direct field set-up of the specific configuration in accordance to local regulation is available for all major countries.

...and all the AURORA BENEFITS

- Dual input section to process two strings with independent MPPT, optimize energy harvesting from multiple arrays oriented in different directions.
- High speed (1 sec) and precise (>99,9%) MPPT algorithm for real time power tracking and improved energy harvesting.
- High efficiencies deliver more energy - up to 96,4% (Euro 96%).
- Watertight IP65 enclosure and full rated power available up to 45°C ambient temperature. Uncompromized performance under the harshest environmental conditions.
- Front-panel mounted LCD display with 4-button keypad provides real-time updates for all operating parameters and laptop-free inverter set-up.
- RS-485 communication interface (for connection to laptop or datalogger).
- Compatible with PVI-RADIOMODULE for wireless communication with Aurora PVI-DESKTOP.
- Integrated DC switch in compliance with VDE 0100-712 (Germany) and CEI 64-8 V4 (Italy), (PVI-3.8-I-OUTD-S & PVI-4.6-I-OUTD-S).
- Standard DC Multi-Contact terminals (model MC4) with mating cable connectors included.

STANDARDS AND CODES

Aurora inverters comply with standards set for grid-tied operation, safety and electromagnetic compatibility including: VDE0126, CEI 11-20 IV ed, DK5940, IEC 61683, IEC 61727, EN50081, EN50082, EN61000, CE certification, El Real Decreto RD1663/2000 de España.

Block Diagram

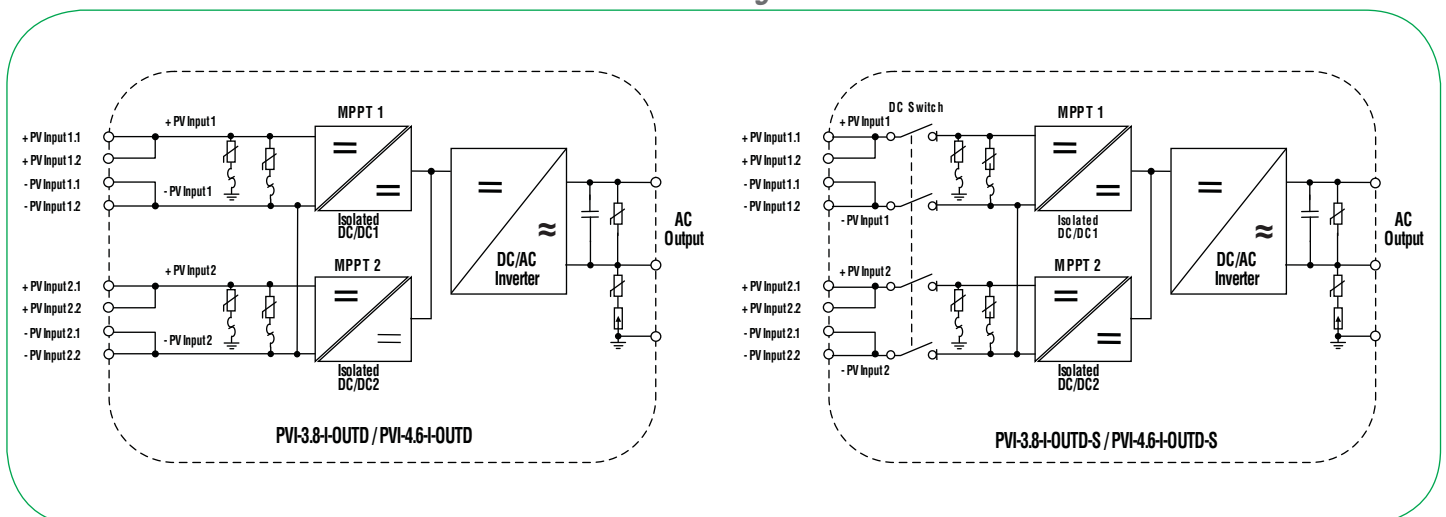

CHARACTERISTICS	PVI-3.8-I-OUTD	PVI-4.6-I-OUTD
INPUT PARAMETERS		
Nominal DC Power [kW]	4.00	4.80
Max. Recommended DC Power [kW]	4.40	5.30
Operating Input Voltage Range [V]	0,7xVstart - 540 (360 nominal)	
Full Power MPPT input voltage range (symmetrical load) [V]	210-480	240-480
Full asymmetrical load input voltage range [V]	210-480 (@ 2,6kW) / 112-480 (@ 1,4kW) / 240-480 (@ 3kW) / 130-480 (@ 1,8kW)	
Max. Input Voltage [V]	540 (560Vpk - not operating condition)	
Activation voltage "Vstart" [V]	200 nominal (adjustable within the range 120Vdc-350Vdc, independently/each input)	
No of independent MPPT trackers	2	3
Max. Input Power, each MPPT [kW]	2,6	3
No. of DC Inputs	4 (2 for MPPT1, 2 for MPPT2)	
Max. DC Current, each MPPT [A]	12,5 (15,6 short circuit)	14 (17 short circuit)
DC Connection	8 (4 positive, 4 negative) MultiContact Ø 4mm (male - positive input + female - negative input) Mating cable connector included Conductor cross section: 4-6mmq/AWG12-10 - Cable Ø w/insulator: 3-6mm	
INPUT PROTECTION		
Reverse polarity protection	Yes	
Fuse rating, each input (-FS suffix versions only)	NA	NA
Thermally Protected DC side varistor	4 (2 for each MPPT)	
PV array Insulation Control (ungrounded applications)	Yes	
"Ground fault protection (for positive-grounded or negative-grounded arrays)"	Integral 1A fuse with GFDI (Ground Fault Detection & Interruption, acc. to UL1741)	
DC Switch (-S/-FS suffix versions only)	Integrated (Max. Voltage Rating : 600Vdc / Max Current Rating: 25A)	
OUTPUT PARAMETERS		
Nominal AC Power (up to 45°C, kW)	3,8	4,6
Max. AC Power [kW]	4,18	5,06
AC Grid Connection	single phase (Live, Neutral, PE)	
Nominal AC Voltage Range [V]	200-245 (230 nominal)	
Maximum AC Voltage Range [V]	180-264 (may vary to comply with regulations in each country)	
Nominal AC Frequency [Hz]	50	
Max. AC Line Current [A]	19 (21 short circuit)	22,5 (25 short circuit)
AC Connection	Screw terminal block Conductor cross section: Solid 0,5-16mmq / Stranded: 0,5-10mmq / AWG20-6 Cable Gland: M32 - Cable Ø: 13-21mm	
Line Power Factor	1	
AC Current Distortion [THD%]	<3,5% at rated power with sine wave voltage	
OUTPUT PROTECTION		
AC side varistors	2 (Live - Neutral / Live - PE)	
Residual current monitoring unit (AC + DC leakage current)	NA	
CONVERSION EFFICIENCY		
Max. Efficiency	96,40%	
Euro Efficiency (preliminary)	96,00%	
ENVIRONMENTAL PARAMETERS		
Cooling	Natural cooling	
Ambient Temp. Range [°C]	-25 / + 60 (output power derating above 45°C)	
Operating Altitude [m]	2000	
Acoustical Noise [dBA]	< 50 @ 1mt	
Environmental IP Rating	IP65	
Relative Humidity	0-100% condensing	
MECHANICAL		
Dimensions [H x W x D]	650 x 325 x 208	
Weight [kg]	24,5	
OTHER		
Stand-By Consumption [W]	8	
Feed In Power Threshold [W]	20	
Night Time consumption [W]	0,1	
Isolation	High frequency transformer	
Display	YES (Alphanumeric 2 lines)	
Communication	RS485 (Screw terminal block - Conductor cross section: 0,08-1,5mmq/AWG28-16) "Aurora Easy-Control" system for remote control (Optional)	
AVAILABLE PRODUCT VARIANTS		
Standard - no options	PVI-3.8-OUTD	PVI-4.6-OUTD
With DC switch	PVI-3.8-OUTD-S	PVI-4.6-OUTD-S
With DC switch and blocking diode/each input	NA	NA

MODEL SUMMARY

MODEL NUMBER	AC POWER
PVI-3.8-I-OUTD	3.8 kW
PVI-3.8-I-OUTD-S	3.8 kW
PVI-4.6-I-OUTD	4.6 kW
PVI-4.6-I-OUTD-S	4.6 kW

OPTIONS

Aurora Communicator software simplifies monitoring via PC.
Aurora Easy Control datalogger is available for remote control via Internet.